



MEDICAL GRADE TREADMILLS

Full Vision, Inc.

3017 Full Vision Drive
Newton, KS 67114

Phone: 316-283-3344

Fax: 316-283-9522

www.trackmastertreadmills.com

URGENT Field Safety Notice

**Trackmaster Treadmills
FSCA 20230519
FSCA**

Date: 2023-05-19

Attention: Users and operators of Trackmaster Treadmills built between May 27, 2022 thru April 10, 2023.

The purpose of this letter is to advise you that Full Vision is conducting a field safety corrective action and to notify you of an intermittent, unexpected occurrence with certain Full Vision medical treadmills (see Table 1 affected products section of this letter). We have completed the root cause investigation and are advising you of a corrective action at this time. Please ensure all individuals in your organization are made aware of this notification and the actions below.

Intended Use:

The medical treadmills are intended as stressing devices, by providing motion to patient, to be interfaced with a variety of cardiac and pulmonary stress testing systems. The treadmill is intended to be operated by the physician, therapist, or operator acting under authorization of the physician with training per IFU under the supervision of a physician and / or therapist, with sufficient knowledge of the indications and contraindications. The medical treadmills are intended to be used in a medical facility or wellness center.

Certain models have a control panel to operate the treadmill.

Caution: Treadmill does not provide any kind of medical treatment diagnostic or assessment.

Table 1 Affected Products:

Model #	Description	UDI-DI
317-07926	TREADMILL TMX428 110V	00860176000606
317-07927	TREADMILL TMX428 220V	00860176000613
317-07928	TREADMILL TMX428CP 110V	00860176000620
317-07929	TREADMILL TMX428CP 220V	00860176000637
317-07926GE	TREADMILL GE T2100-ST1 110V	00860176000668
317-07927GE	TREADMILL GE T2100-ST2 220V	00860176000675
317-07927GE CHINA	TREADMILL GE T2100-ST2 220V CHINA	00860176000675

See **Appendix A** for location of decal. Serial numbers are located on the front of the device.

Serial number range:

GEDC-6608 thru GEDC-8382	FVDC-7585 thru FVDC-7601	FVDC-7603 thru FVDC-7631	FVDC-7633 thru FVDC-7819
FVDC-7825 thru FVDC-7890	FVDC-7899 thru FVDC-7958	FVDC-7964 thru FVDC-8056	FVDC-8064 thru FVDC-8068
FVDC-8104 thru FVDC-8185	FVDC-8190 thru FVDC-8387	FVDC-8389 thru FVDC-8392	FVDC-8396 thru FVDC-8399
FVDC-8407 thru FVDC-8412	FVDC-8414 thru FVDC-8420	FVDC-8426 thru FVDC-8445	FVDC-8456 thru FVDC-8547
FVDC-8552	FVDC-8554 thru FVDC-8556	FVDC-8558 thru FVDC-8618	FVDC-8629 thru FVDC-8650
FVDC-8654 thru FVDC-8701	FVDC-8727 thru FVDC-8731	FVDC-8757 thru FVDC-8767	FVDC-8784 thru FVDC-8803
FVDC-8805 thru FVDC-8810	FVDC-8812 thru FVDC-8816	FVDC-8819 thru FVDC-8828	FVDC-8849
FVDC-8860 thru FVDC-8869	FVDC-8885 thru FVDC-8886	FVDC-8888	

Description of the problem:

Trackmaster treadmills manufactured between May 27, 2022 thru April 10, 2023 are equipped with the updated Motor/Drive PCB assembly which provides motion to the running belt. When given a start command from the integrated controller or attached stress system, the Drive and Motor is intended to accelerate at speed transitions (acceleration and deceleration) of 0.5mph/sec and the threshold for causing an error code is opened up to 2.5mph/sec where if the Drive detects a transition greater than this, the treadmill shuts down and creates error code 8. Once target speed is reached the threshold is reduced to 0.5mph/sec where if the Drive detects a transition greater than this, the treadmill shuts down and creates error code 8. These thresholds are controlled through the firmware application of the Drive and Smart Power Supply Board. In the potential event the treadmill accelerates or decelerates faster than expected, the patient is required to wear a safety tether that stops the treadmill in the event of a fall, as well as access to an emergency stop button as the main emergency stop method. It has been reported that during operation, the treadmill accelerated rapidly after the user commanded the treadmill to start movement and sustain 1 mph, where as soon as the treadmill was started, walking belt speed accelerated abruptly for less than a second before triggering an error creating a coast to stop due to the speed mismatch controls. This rapid acceleration is not the desired operation. It has also been reported that during operation, the treadmill started moving in reverse before rapidly accelerating forward after the user commanded the treadmill to start movement of the belt and sustain a set speed. Also, during operation in later stages of the test, the treadmill can come to a controlled yet unexpected coast to stop. It has been identified that the updated Motor/Drive PCB configuration has inherent noise between the encoder on the Motor and the Drive PCB which may cause the Drive PCB to misread the orientation of the Motor when commanded to start movement. Based on what degree out of phase the Drive PCB reads is the result of the acceleration or reverse motion and speed at which this occurs. Also, during changes of state of the Drive PCB while the treadmill is in motion, the Drive PCB can misread the signals and stop the treadmill unexpectedly.

Risk to Health:

If the treadmill accelerates or stops rapidly the patient could fall and may come in contact with the belt suffering a temporary injury. The treadmill has safety controls in place to limit the acceleration through firmware of the drive PCB and Smart Power Supply Board, but the risk is there that sudden, rapid belt movement over a 1 second period or less could still cause a fall. The patient should always wear the safety tether to limit the duration of contact with the belt or extent of injury. The Emergency Stop Button is the primary means of stopping the device in an emergency stopping scenario with the safety tether as a secondary stopping method in the event of a fall. In addition, the operator assisting the patient should be stationed within reach of the Emergency Stop Button and is there to assist the patient in the event of an emergency stopping scenario as other means of risk mitigation.

Actions to be taken by the Customer/User:

Full Vision has put the treadmills on a production hold as of April 10, 2023 and a shipping hold as of April 27, 2023. The actions to be taken by the users as detailed in the customer letter will prevent injuries as a result of the unexpected rapid acceleration and reverse motion of the belt. This will not prevent the uncommanded coast to stop of the belt that is occurring during operation, but due to the coast to stop

method, the patient has to cool down before repeating the test, but there is very little risk of injury. There have been no reported injuries due to uncommanded coast to stop.

Immediate Actions to be taken by Customer/User:

These steps are the recommendation of the Manufacturer to prevent injury and allow use of the device.

Step 1: Instruct patient to straddle the belt and hold on to the handrails during initialization of the treadmill before starting the test

Step 2: Send start/run command to the treadmill with patient still straddling the belt, wait 30 seconds to ensure there is no uncommanded motion

Step 3: Instruct patient to carefully step on the belt while holding on to the handrails, begin walking and continue with the test

Step 4: Patients unable to perform steps 1-3 must not use the treadmill

Step 5: **Print Appendix B and attach to the treadmill until corrections are made and ensure it is visible to the clinician and user**

Product Correction:

Full Vision or the Distributors/Service Centers will perform the following field actions:

Step 1) update the drive PCB with updated firmware

Step 2) install a ground wire between the motor and drive to reduce the noise

Step 3) update the firmware on the Smart Power Supply Board on all treadmills with the updated motor/drive PCB assembly

Step 4) perform calibration of the treadmill and ensure the correct firmware is installed

Step 5) complete the completion response form for the serial number corrected

Transmission of this Field Safety Notice:

This notice needs to be passed on to all those who need to be aware within your organisation or to any organisation where the potentially affected devices have been transferred.

Contact reference person:

Doug Pauls

Full Vision Inc

3017 Full Vision Drive

Newton, KS 67114 USA

316-283-3344

dp@full-vision.com

vigilance@full-vision.com

The undersign confirms that this notice has been provided to the appropriate Regulatory Agency.

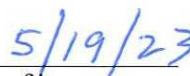
	
_____ Signature	_____ Date of issue
_____ Doug Pauls	_____ Newton, KS
_____ Name	_____ Place of Issue

Appendix A

See images below for reference to identify the serial # of your device(s).

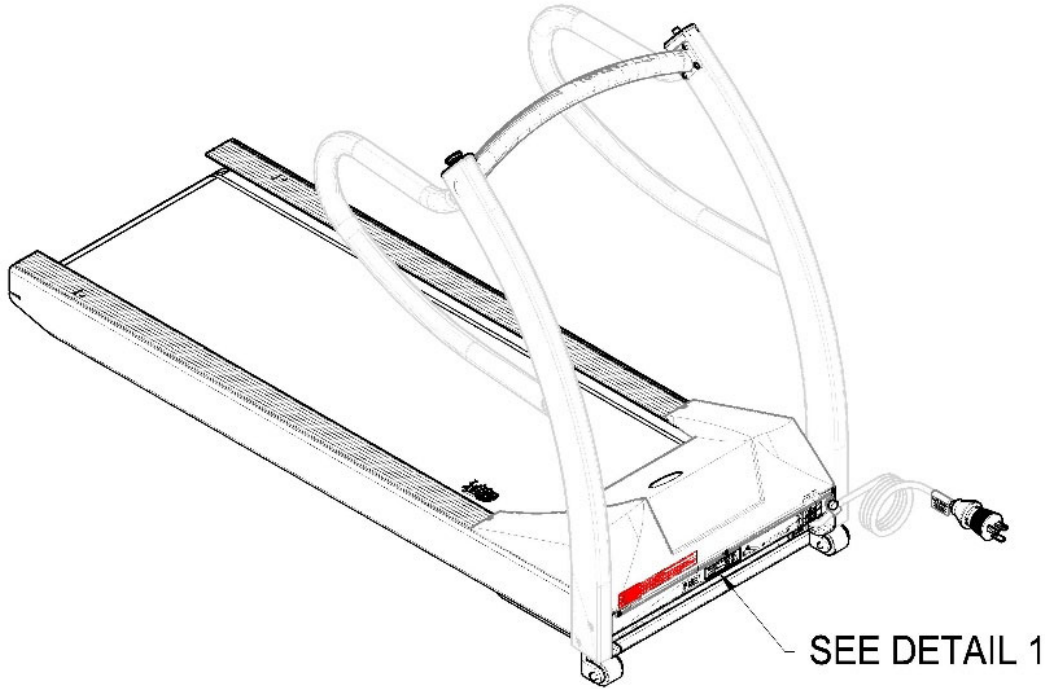

DETAIL 1

MODEL NO. T2100-STX SN GEDC-XXXX REF 2097357-XXX <small>Private Label MFG: GE Medical Systems Information Technologies, Inc 9900 Innovation Drive Wauwatosa, WI 53226, USA</small>	MFG MODEL NO. TMX428 XXX MFG PART NO. 317-079XX GE VOLTAGE: XXX XXXX ~ AMPS: XX HERTZ: XX <small>YYY-MM-DD</small>	<small>ETL CLASSIFIED</small> <small>Intertek 3052192</small> CONFORMS TO AAMI STD ES60601-1 IEC STD 60601-1-6 CERTIFIED TO CSA C22.2 # 60601-1 	UDI (01) UDI (11) UDI DATE (21) UDI SN <small>SERIAL NUMBER</small> <small>B-CODESN</small>
<small>4TH EDITION PRODUCTION</small> 2097357-XXX REV XX 			

Enlarged image of serial number decal

MODEL NO. T2100-STX SN GEDC-XXXX REF 2097357-XXX <small>Private Label MFG: GE Medical Systems Information Technologies, Inc 9900 Innovation Drive Wauwatosa, WI 53226, USA</small>	MFG MODEL NO. TMX428 XXX MFG PART NO. 317-079XX GE VOLTAGE: XXX XXXX ~ AMPS: XX HERTZ: XX <small>YYY-MM-DD</small>	 3017 FULL VISION DRIVE, NEWTON, KANSAS USA 67114-9750
---	--	--

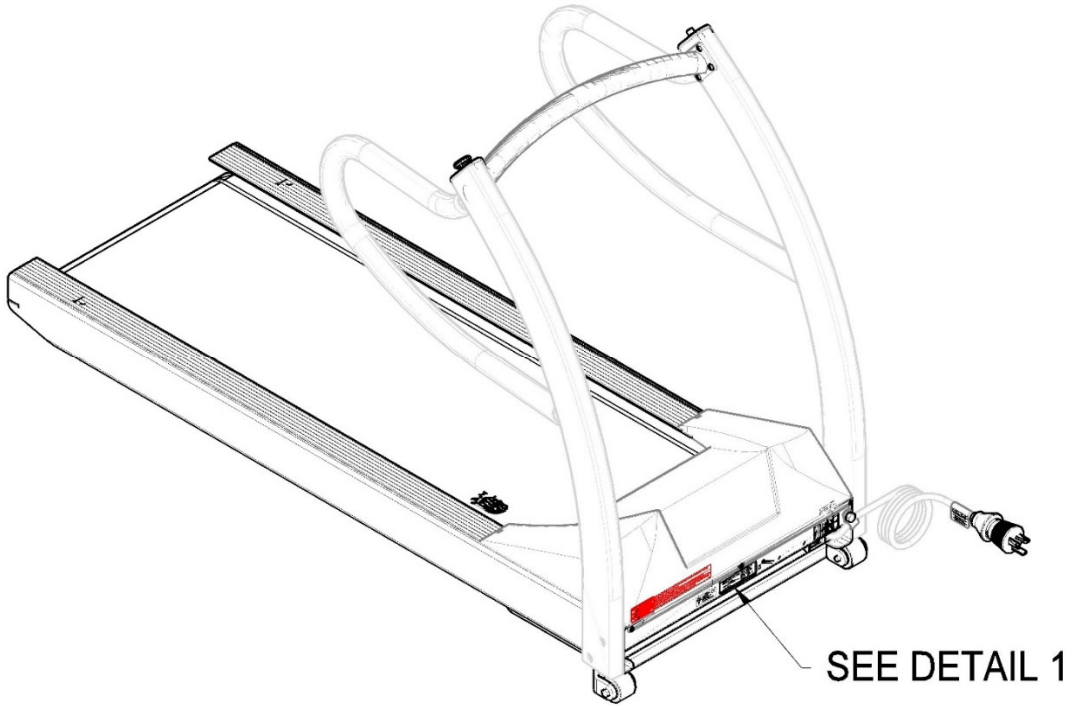

DETAIL 1

<p>ETL CLASSIFIED  CONFORMS TO AAMI STD ES60601-1 IEC STD 60601-1-6 CERTIFIED TO CSA C22.2 # 60601-1 Intertek 3062192</p>	<p>TRACKMASTER  FULL VISION INC. 3017 FULL VISION DRIVE, NEWTON, KANSAS 67114-9750 MADE IN USA YYYY-MM-DD</p>	<p>UDI  (01) 0086017600XXXX (11) YYYYMMDD (21) FVDC-XXXX MD </p>
<p>4TH EDITION PRODUCTION</p>		

Enlarged image of serial number decal

<p>TRACKMASTER  FULL VISION INC. 3017 FULL VISION DRIVE, NEWTON, KANSAS 67114-9750 MADE IN USA YYYY-MM-DD</p>	<p>MODEL NO. TM328 XXX XX PART NO. 317-XXXXX SERIAL NO. FVDC - XXXX VOLTAGE: XXX XXX ~ AMPS: XX HERTZ: XX</p>
--	--

Print this page and attach to the treadmill until corrections are made.

Immediate Actions to be taken by Customer/User:

These steps are the recommendation of the Manufacturer to prevent injury and allow use of the device.

Step 1: Instruct patient to straddle the belt and hold on to the handrails during initialization of the treadmill before starting the test

Step 2: Send start/run command to the treadmill with patient still straddling the belt, wait 30 seconds to ensure there is no uncommanded motion

Step 3: Instruct patient to carefully step on the belt while holding on to the handrails, begin walking and continue with the test

Step 4: Patients unable to perform steps 1-3 must not use the treadmill
